

We can't guarantee you'll never have to replace a meter post again, but we can guarantee the next time you send a crew out it will be the easiest job they've done all day.

Introducing the new WEDGE-LOK post mounting system, new from POM.

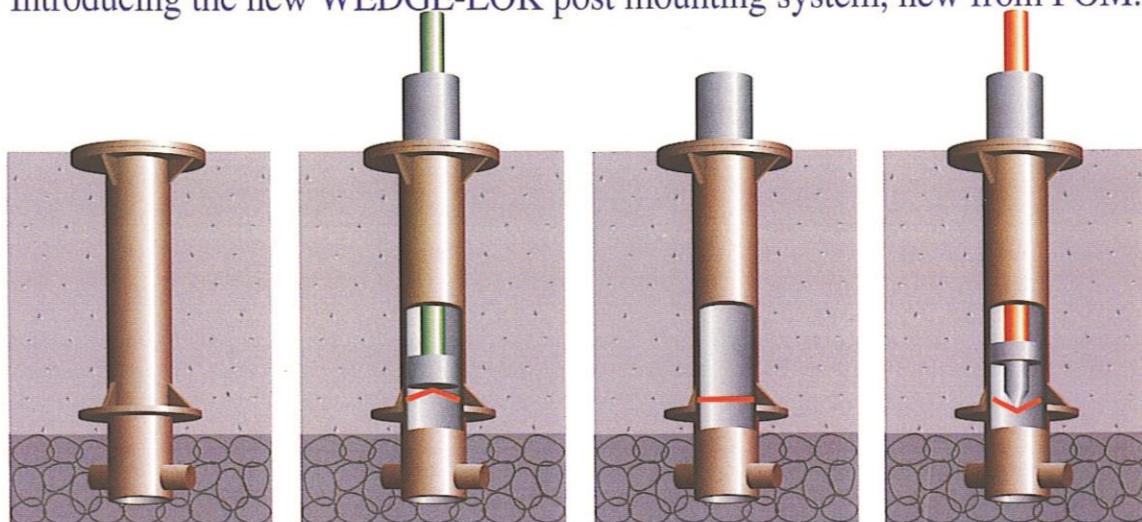

1 The post anchor sleeve is set in a hole with loose, coarse gravel. Quick setting concrete is then poured around it. The sleeve is flush with the street or sidewalk.

2 To install the post, a bent wedge is inserted in the post slot with the bend pointed upward. The post is inserted into the anchor socket.

3 An installation tool with a wide, flat end is driven down through the post, flattening the wedge so that it spreads out through the slot to anchor the post.

4 To remove a damaged post simply re-bend the wedge with a removal tool and the wedge falls to the bottom, then simply remove the post from the anchor socket.

Repairing a damaged meter post has always been a task loaded with time, effort, money and manpower. Now, thanks to POM and the new WEDGE-LOK post mounting system, those rules no longer apply.

With the WEDGE-LOK system you install your base sleeve and when a post is damaged you simply pull out the damaged post and insert a new one.

The big question is, "is it really that simple"? And the answer is an unqualified "yes, it is that simple".

But we have much more to tell you about the new WEDGE-LOK system. And, if you'll call us toll-free, we will. The new WEDGE-LOK post mounting system from POM, it's a simple design that quite simply will save you time and money.



P.O. BOX 430 • 200 South Elmira Avenue • Russellville, AR 72802 • Phone 479-968-2880 • FAX 479-968-2840

Call Toll Free 1-800-331-PARK

Wedge-Lok Post Mounting Device Installation Instructions

Dig an 18" diameter hole to a depth of 18". With a temporary plastic cap covering the bottom end of the anchor socket, set the anchor socket in the hole with the top level to the ground, and fill the bottom of the hold around it with coarse gravel to 2" deep. This will facilitate drainage and keep wet concrete from coming up into the bottom of the anchor socket during setting.

Concrete: We recommend a minimum 3,000 psi Portland concrete mix to meet ASTM C-31 specifications. Minimum cement 511 lbs per yard. Mix concrete and pour around the anchor socket, filling the hole flush with the ground and top of the anchor socket.

Remove the cap covering the top of the anchor socket and insert a post for leveling the anchor socket in the wet concrete. When level, remove the post and allow the concrete to set up and dry in the hole.

Before installing the post, insert a long, pointed bar or other object in the anchor socket and punch a few drainage holes in the plastic cap covering the bottom of the anchor socket.

Insert the wedge into the slot machined in the post, with the bend pointing upward toward the top of the post. Wrap a piece of thin tape around the post covering the slots, to keep the wedge in place. Apply a layer of grease around the exterior surface of the post that will be inserted into the anchor socket. Insert the end of the post in the anchor socket and turn until it seats firmly on the locator bar in the bottom of the anchor socket. See Drawing B.

Insert the installation tool (with the flat end attachment) and holding the T-handles, drive downward two or three times to flatten the wedge inside the pipe, through the slots in the pipe and into the groove inside the anchor socket. See Drawings C and D. The post will feel tight and secure within the anchor socket. Remove the installation tool and install the parking meter onto the post.

To remove the post, remove the parking meter. Insert the removal tool (with the pointed attachment--See Drawing E) and holding the T-handles, drive downward two or three times to bend the wedge until it falls down into the bottom of the anchor socket (see Drawings F and G). Withdraw the removal tool. Pull and twist the post until it is out of the anchor socket. Reach in to withdraw the bent wedge and discard it.

Now the anchor socket is ready for installation of another post/wedge assembly.

PDM
200 SOUTH ELMIRA AVE.
RUSSELLVILLE, AR 72801

